

Purdue University - ITaP Research Computing

Gladys Andino

Dan Dietz

Jieyu Gao

Lev Gorenstein

Erik Gough

Stephen Harrell

Randy Herban

Steve Kelley

Boyu Zhang

Xiao Zhu

Eric Adams

rcac-help@purdue.edu

April 2, 2021

Slides available:

www.rcac.purdue.edu/training/clusters101/

Vocabulary

Connecting

Modules

Types of Work

Good
Citizenship

Jobs, Queues,
and SLURM

Vocabulary

Connecting

- Windows
- Mac
- Linux

Modules

Types of Work

- Serial vs Parallel
- Parallel Computations

Good Citizenship

Jobs, Queues, and SLURM

- Jobs
- Queues
- SLURM
- Life of a Job

Vocabulary

Connecting

Modules

Types of Work

Good
Citizenship

Jobs, Queues,
and SLURM

A few additional acknowledgments to the many people who have helped make this workshop possible.

- The material in this workshop was prepared by the Purdue University ITaP Research Computing team.

Vocabulary

Vocabulary

Connecting

Modules

Types of Work

Good
Citizenship

Jobs, Queues,
and SLURM

Vocabulary

Vocabulary

Vocabulary

Connecting

Modules

Types of Work

Good

Citizenship

Jobs, Queues,
and SLURM

A cluster is a cluster is a cluster?

- Hardware (compute nodes + interconnect + storage)
- Software (OS + compilers + libraries + apps + queue manager)
- Infrastructure (front-ends + power + cooling + data center + staff)



Vocabulary

Vocabulary

Connecting

Modules

Types of Work

Good
Citizenship

Jobs, Queues,
and SLURM

Node:

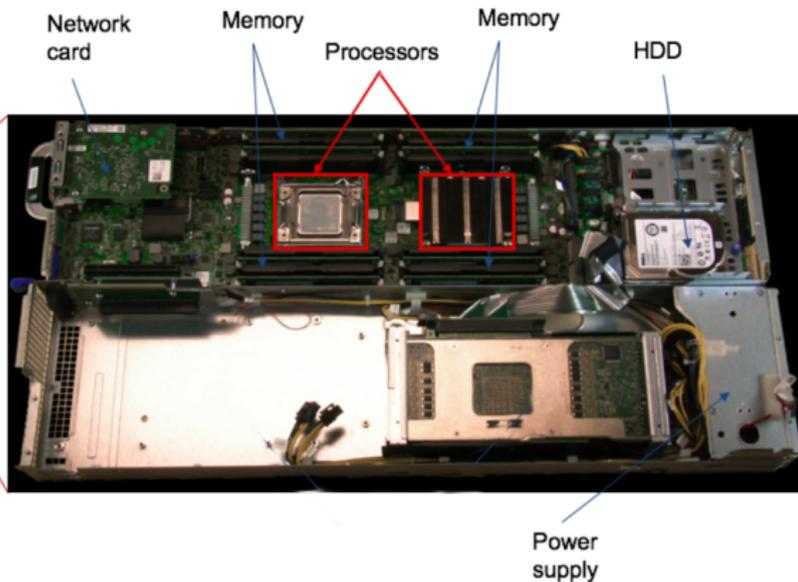
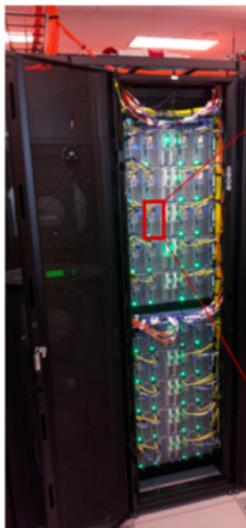

Vocabulary

Vocabulary

Connecting

Modules

Types of Work

Good
Citizenship

Jobs, Queues,
and SLURM

CPU:

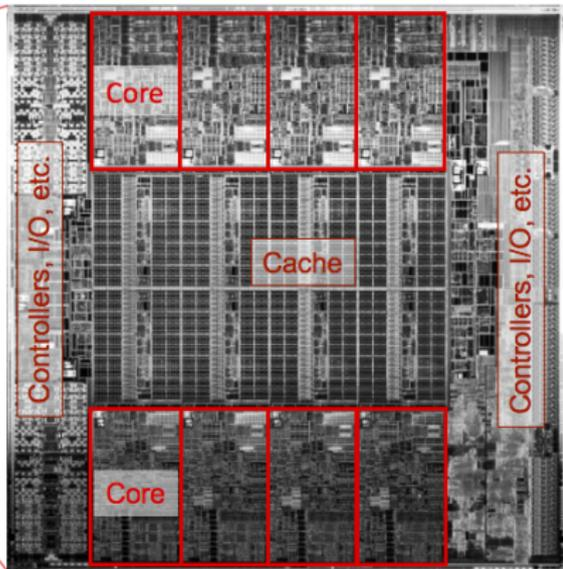
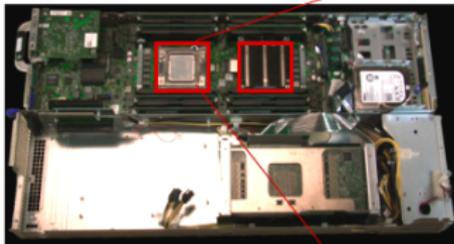

Vocabulary

Vocabulary

Connecting

Modules

Types of Work

Good
Citizenship

Jobs, Queues,
and SLURM

Processor Core: individual compute unit ("slot") on the chip

- You see:
 - 2 physical processors, 10 cores ea.
- Queuing system sees:
 - 20 logical processors
- From now on, we will be mostly concerned with cores (logical processors), not physical chips ("I ran on 5 CPUs" == "on 5 processors" == "on 5 cores")

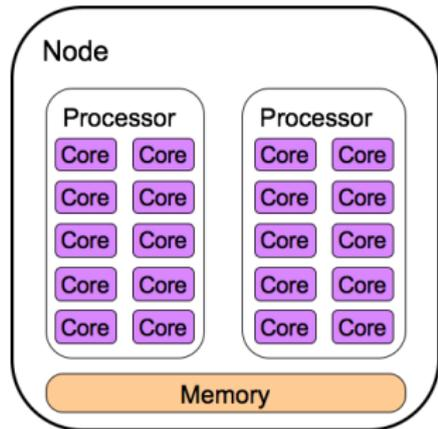

Vocabulary

Vocabulary

Connecting

Modules

Types of Work

Good
Citizenship

Jobs, Queues,
and SLURM

Front-end vs compute node:

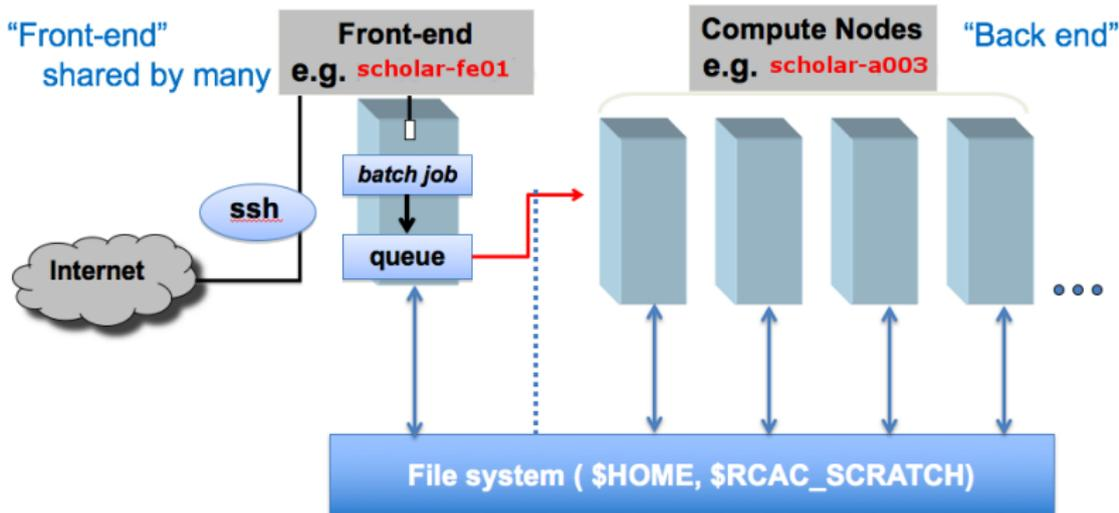

Running Jobs: most common The goal is getting to the compute nodes

Vocabulary

Vocabulary

Connecting

Modules

Types of Work

Good
Citizenship

Jobs, Queues,
and SLURM

IBM SYSTEM 360 (1 Computer, 1 Processor):



Vocabulary

Vocabulary

Connecting

Modules

Types of Work

Good
Citizenship

Jobs, Queues,
and SLURM

Community clusters:

HPC (Halstead, Brown, Bell): Multiple cores or nodes, probably MPI. Benefit from high-performance network and parallel filesystem. The vast majority of campus - 80% of all work!

GPU Accelerated (Gilbreth): Utilizes Nvidia P100 and V100 GPUs for acceleration. Useful for Machine Learning, AI, Computational Chemistry, etc.

Scholar: Special case for teaching. Mostly MPI at first glance, but also highly tweaked for interactive use (tasks on front-ends, Jupyter notebooks, Rstudio, etc). Also couple GPUs and mini-Hadoop.

Vocabulary

Vocabulary

Connecting

Modules

Types of Work

Good
Citizenship

Jobs, Queues,
and SLURM

Need help with ITaP Research Computing resources?

Check our User Guides and documentation:

www.rcac.purdue.edu/knowledge

You can always send us an email:

rcac-help@purdue.edu

Come to our coffee hour consultations:

www.rcac.purdue.edu/coffee

Connecting

Vocabulary

Connecting

Windows

Mac

Linux

Modules

Types of Work

Good

Citizenship

Jobs, Queues,
and SLURM

Connecting

- Windows
- Mac
- Linux

Connecting

Windows

Vocabulary

Connecting

Windows

Mac

Linux

Modules

Types of Work

Good

Citizenship

Jobs, Queues,
and SLURM

Many clients are available for Windows:

- We will use the PuTTY SSH client
- Download PuTTY, no install required
- <http://www.chiark.greenend.org.uk/~sgtatham/putty/download.html>
(or Google search *putty*)
- Download `putty.exe` for Intel x86 to your desktop

Connecting

Windows

Vocabulary

Connecting

Windows

Mac

Linux

Modules

Types of Work

Good

Citizenship

Jobs, Queues,
and SLURM

Host Name for Scholar is `scholar.rcac.purdue.edu`

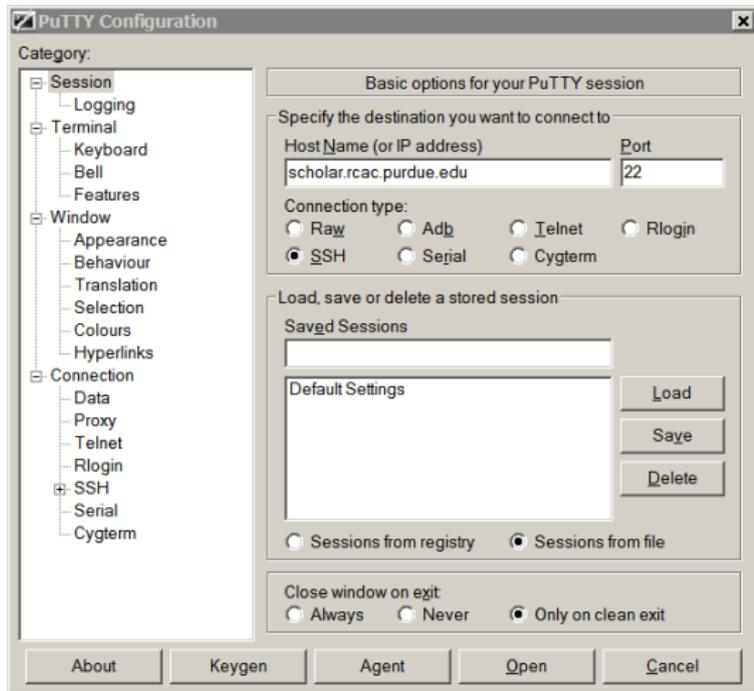

Connecting

Mac

Vocabulary

Connecting

Windows

Mac

Linux

Modules

Types of Work

Good

Citizenship

Jobs, Queues,
and SLURM

Connect using:

```
ssh myusername@scholar.rcac.purdue.edu
```

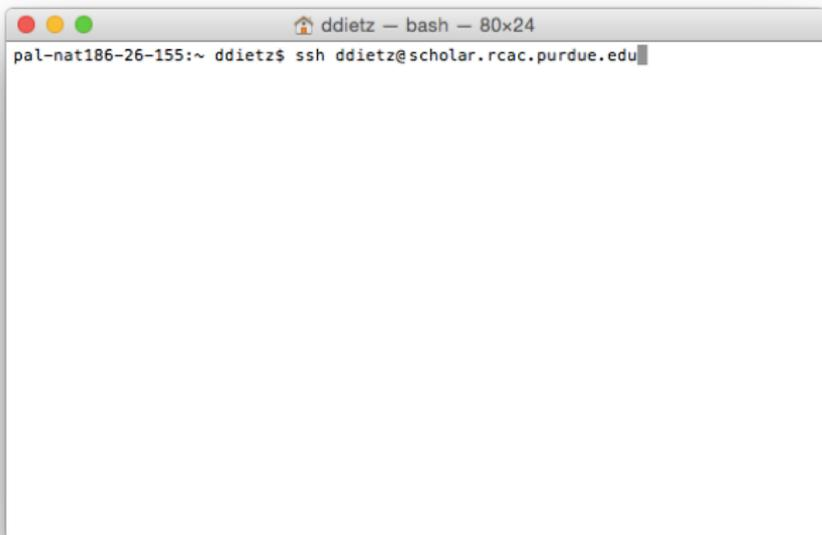

A terminal window titled "ddietz -- bash -- 80x24" with a home icon. The prompt is "pal-nat186-26-155:~ ddietz\$". The command "ssh ddietz@scholar.rcac.purdue.edu" is entered and highlighted with a cursor at the end.

Connecting

Linux

Vocabulary

Connecting

Windows

Mac

Linux

Modules

Types of Work

Good

Citizenship

Jobs, Queues,
and SLURM

Linux also has a built in terminal client, similar to Mac:

```
ssh myusername@scholar.rcac.purdue.edu
```

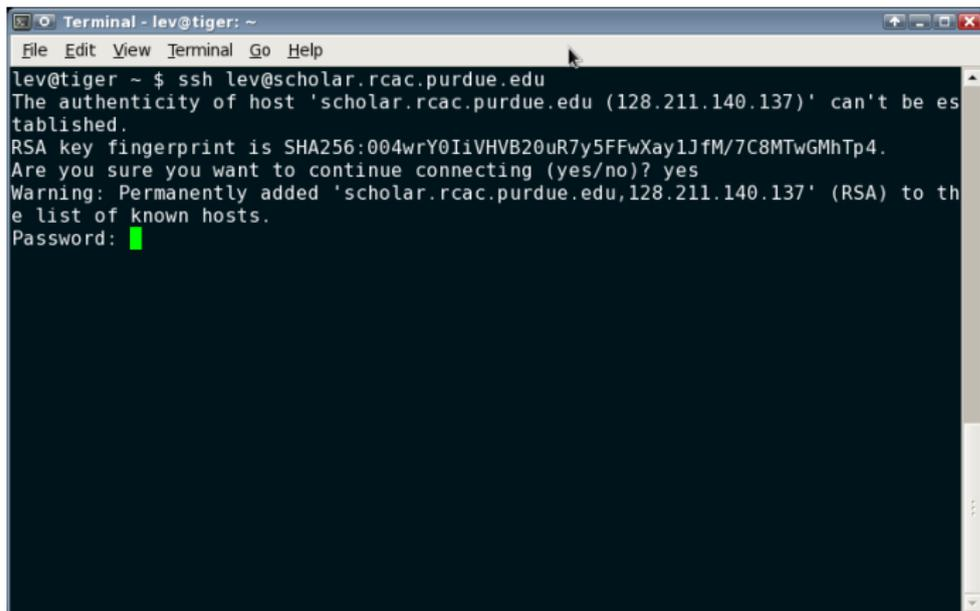

```
Terminal - lev@tiger: ~
File Edit View Terminal Go Help
lev@tiger ~ $ ssh lev@scholar.rcac.purdue.edu
The authenticity of host 'scholar.rcac.purdue.edu (128.211.140.137)' can't be es
tablished.
RSA key fingerprint is SHA256:004wrY0IiVHVB20uR7y5FFwXay1JfM/7C8MTwGMhTp4.
Are you sure you want to continue connecting (yes/no)? yes
Warning: Permanently added 'scholar.rcac.purdue.edu,128.211.140.137' (RSA) to th
e list of known hosts.
Password: █
```

Modules

Vocabulary

Connecting

Modules

Types of Work

Good
Citizenship

Jobs, Queues,
and SLURM

Modules

Modules

Vocabulary

Connecting

Modules

Types of Work

Good
Citizenship

Jobs, Queues,
and SLURM

All ITaP Research Computing clusters use a module system

- Module system provides for the dynamic modification of a user's environment
- Module commands allow you to add applications and libraries to your environment
- This allows us to simultaneously and safely provide several versions of the same software
- You can set up the environment for running applications using simple commands:

```
$ module load gcc  
$ module load openmpi
```

- All ITaP Research Computing clusters have a default programming environment (compiler and MPI library) loaded for you when you log in.

Modules

Vocabulary

Connecting

Modules

Types of Work

Good

Citizenship

Jobs, Queues,
and SLURM

Show all modules currently loaded in my environment:

```
$ module list
```

```
Currently Loaded Modules:
```

```
  1) intel/17.0.1.132  2) impi/2017.1.132  3) rcac
```

Load a new module:

```
$ module load matlab
```

```
$ module list
```

```
Currently Loaded Modules:
```

```
  1) intel/17.0.1.132  2) impi/2017.1.132  3) rcac  
  4) matlab/R2017a
```

Modules

Vocabulary

Connecting

Modules

Types of Work

Good
Citizenship

Jobs, Queues,
and SLURM

Shows you all software modules currently available to you:

```
$ module avail
```

Filters software modules currently available to you by a search term. In this case, show all Anaconda Python versions available:

```
$ module avail anaconda
```

```
----- Core Applications -----  
anaconda/5.0.0-py27      anaconda/5.1.0-py27 (D)  
anaconda/5.0.0-py36      anaconda/5.1.0-py36
```

Modules

Vocabulary

Connecting

Modules

Types of Work

Good
Citizenship

Jobs, Queues,
and SLURM

All ITaP Research Computing clusters use an hierarchical software configuration. Modules are organized by the programming environment (compiler and libraries) that they were built with and depend on. You will only see (with `avail`) modules compatible with the programming environment currently loaded.

As you swap in other programming environments (compiler and libraries), you may find additional software available to you. Any libraries or software dependent on the programming environment will be automatically swapped with compatible versions as you change environments.

Modules

Vocabulary

Connecting

Modules

Types of Work

Good
Citizenship

Jobs, Queues,
and SLURM

We can look for software not immediately available to us - that is, things that may not show up in `avail` output:

```
$ module avail openmpi
$ module spider openmpi
```

```
-----
openmpi:
-----
```

```
  Versions:
    openmpi/2.1.0
```

For detailed information about a specific "openmpi" module (including how to load the modules) use the module's full name. For example:

```
$ module spider openmpi/2.1.0
```

This tells that `openmpi` is installed on the cluster, but we must further investigate how to load it.

Modules

Vocabulary

Connecting

Modules

Types of Work

Good

Citizenship

Jobs, Queues,
and SLURM

Running spider command for specific version of openmpi:

```
$ module spider openmpi/2.1.0
```

```
-----  
openmpi: openmpi/2.1.0  
-----
```

You will need to load all module(s) on any one of the lines below before the "openmpi/2.1.0" module is available to load.

```
gcc/4.8.5  
gcc/6.3.0
```

This tells us we must swap into a new programming environment to load openmpi:

```
$ module load gcc/4.8.5 openmpi/2.1.0
```

Modules

Vocabulary

Connecting

Modules

Types of Work

Good

Citizenship

Jobs, Queues,
and SLURM

Unload a currently loaded module:

```
$ module unload matlab
```

```
$ module list
```

```
Currently Loaded Modules:
```

```
1) gcc/4.8.5    2) openmpi/2.1.0    3) rcac
```

Unload and purge all currently loaded modules:

```
$ module purge
```

```
$ module list
```

```
No modules loaded
```

Modules

Vocabulary

Connecting

Modules

Types of Work

Good
Citizenship

Jobs, Queues,
and SLURM

What exactly does `module load` do?

It will change the environmental variables defined for that module. Typically these are `$PATH` and `$LD_LIBRARY_PATH`. Also a few extra module-specific environmental variables could be set.

```
$ module show vmd
-----
  /opt/modulefiles/core/vmd/1.9.3.lua:
-----
whatis("invoke VMD 1.9.3")
setenv("VMD_HOME", "/apps/cent7/vmd/vmd-1.9.3")
prepend_path("PATH", "/apps/cent7/vmd/vmd-1.9.3/bin")
prepend_path("LD_LIBRARY_PATH", "/apps/cent7/vmd/vmd-1.9.3/lib")
setenv("LIBGL_ALWAYS_INDIRECT", "y")
```

Modules

Vocabulary

Connecting

Modules

Types of Work

Good
Citizenship

Jobs, Queues,
and SLURM

A few tips from us:

- Don't load modules in `.bashrc/.profile/.login/.cshrc`
- Don't load more than needed for current task
- Do `module purge` when in doubt
- Do check with `module show` what a given module does
- Do check with `module list` what's actually loaded
- Do script and automate your builds - even if it's just a 3-line snippet! Reproducibility is good!

Modules

Vocabulary

Connecting

Modules

Types of Work

Good
Citizenship

Jobs, Queues,
and SLURM

Exercises:

1. List currently loaded modules
2. List available modules
3. Search available modules for `matlab`
4. Show what one of the `matlab` modules does
5. Load the `openmpi` module (hint: `spider`)
6. Purge all modules
7. List currently loaded modules

Modules

Vocabulary

Connecting

Modules

Types of Work

Good

Citizenship

Jobs, Queues,
and SLURM

Exercises:

1. List currently loaded modules

```
$ module list
```

```
Currently Loaded Modules:
```

```
  1) intel/17.0.1.132  2) impi/2017.1.132  3) xalt (S)  4)  
    rcac
```

2. List available modules

```
$ module avail
```

```
...
```

3. Search available modules for matlab

```
$ module avail matlab
```

```
----- Core Applications -----  
  matlab/R2017a (D)  matlab/R2018a
```

Modules

Vocabulary

Connecting

Modules

Types of Work

Good

Citizenship

Jobs, Queues,
and SLURM

4. Show what one of the matlab modules does

```
$ module show matlab
```

5. Load the openmpi module (hint: spider)

```
$ module spider openmpi
$ module spider openmpi/2.1.0
$ module load gcc/4.8.5 openmpi/2.1.0
Lmod is automatically replacing "intel/17.0.1.132" with "gcc
/4.8.5".
Lmod is automatically replacing "impi/2017.1.132" with "openmpi
/2.1.0".
```

6. Purge all modules

```
$ module purge
```

7. List currently loaded modules

```
$ module list
No modules loaded
```

Types of Work

Vocabulary

Connecting

Modules

Types of Work

Serial vs Parallel

Parallel
Computations

Good
Citizenship

Jobs, Queues,
and SLURM

Types of Work

- Serial vs Parallel
- Parallel Computations

Types of Work

Serial vs Parallel

Vocabulary

Connecting

Modules

Types of Work

Serial vs Parallel

Parallel
Computations

Good

Citizenship

Jobs, Queues,
and SLURM



More than one mower!
Mow the lawn faster ...
... or mow a bigger lawn
Lawn mowers = cores

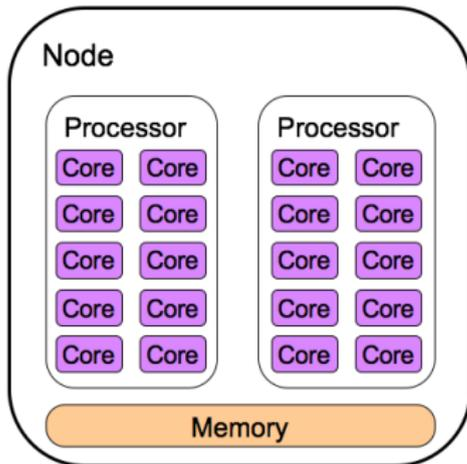

Types of Work

Serial vs Parallel

Vocabulary

Connecting

Modules

Types of Work

Serial vs Parallel

Parallel
Computations

Good

Citizenship

Jobs, Queues,
and SLURM



More than one mower!
Mow the lawn faster ...
... or mow a bigger lawn
Lawn mowers = cores

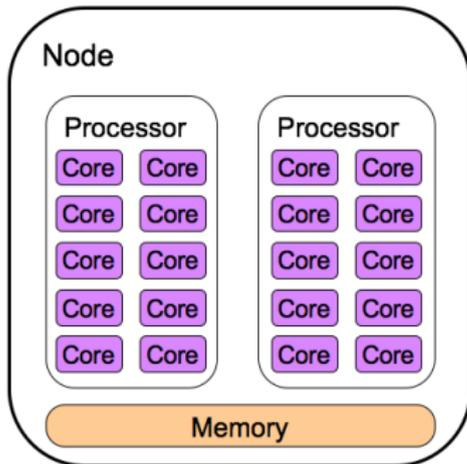

Types of Work

Parallel Computations

Vocabulary

Connecting

Modules

Types of Work

Serial vs Parallel

Parallel
Computations

Good

Citizenship

Jobs, Queues,
and SLURM

Parallel computations come in a few flavors:

- MPI - Message Passing Interface, multiple nodes
- OpenMP - confine yourself to one node
- Hybrid - mix MPI and OpenMP
- Accelerators/coprocessors - GPU, Intel Xeon Phi
- Parallel R, Matlab, Hadoop and Spark

Good Citizenship

Vocabulary

Connecting

Modules

Types of Work

**Good
Citizenship**

Jobs, Queues,
and SLURM

Good Citizenship

Good Citizenship

Vocabulary

Connecting

Modules

Types of Work

Good
Citizenship

Jobs, Queues,
and SLURM

Front-end vs compute node:

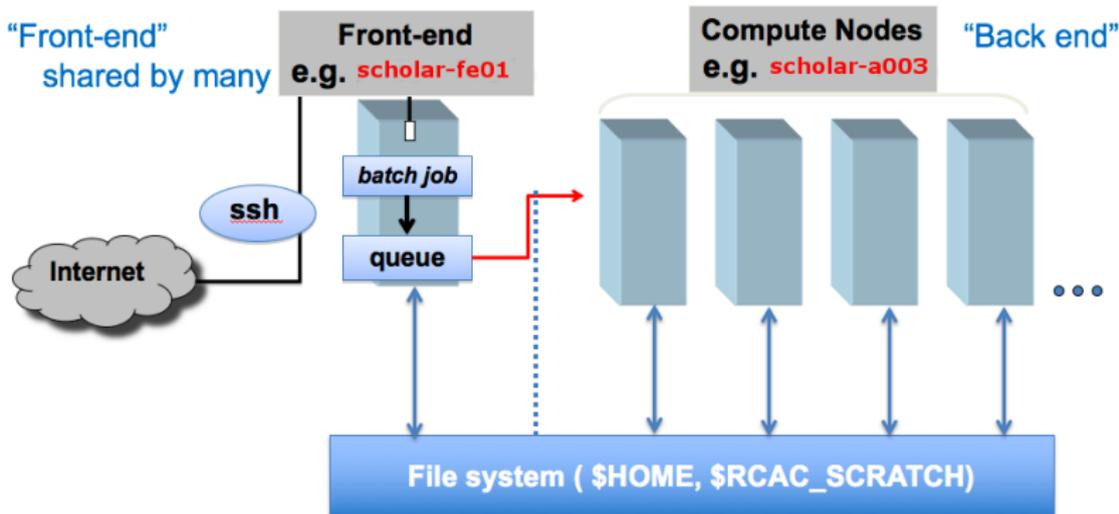

Running Jobs: most common The goal is getting to the compute nodes

Good Citizenship

Vocabulary

Connecting

Modules

Types of Work

Good
Citizenship

Jobs, Queues,
and SLURM

What does this mean?

- Do not do major science on the front end
- Front-ends are very limited resources and you'll annoy the system administrators and other users
- Watchdog will monitor and quickly terminate (or severely throttle) any inappropriate resource-intensive process
- Instead: submit a job. We'll get to that

Good Citizenship

Vocabulary

Connecting

Modules

Types of Work

Good
Citizenship

Jobs, Queues,
and SLURM

What can I do on the front-ends?

- Building/compiling software
- Managing files: editing, transferring, tar, gzip, hsi
- Submitting, monitoring, and managing batch jobs
- Launching interactive jobs
- Modest post-processing and analysis

Scholar is somewhat fortified for interactive use, and you could run some things on its front-ends... but for anything heavy you'd still be much better off submitting a job.

Jobs, Queues, and SLURM

Vocabulary

Connecting

Modules

Types of Work

Good
Citizenship

**Jobs, Queues,
and SLURM**

Jobs

Queues

SLURM

Life of a Job

Jobs, Queues, and SLURM

- Jobs
- Queues
- SLURM
- Life of a Job

Jobs, Queues, and SLURM

Jobs

Vocabulary

Connecting

Modules

Types of Work

Good
Citizenship

Jobs, Queues,
and SLURM

Jobs

Queues

SLURM

Life of a Job

What is a job?

- A job is simply a set of tasks to be performed by a cluster
- A script to instruct the cluster precisely what to do to complete your work
- Self contained to be executed without any interaction
- Submit and forget!

Jobs, Queues, and SLURM

Jobs

Vocabulary

Connecting

Modules

Types of Work

Good
Citizenship

Jobs, Queues,
and SLURM

Jobs

Queues
SLURM

Life of a Job

Remember, cluster front-end nodes are shared resources for

- Creating, submitting, and monitoring jobs
- File transfers
- Preparing inputs
- Editing and compiling code
- Small-scale testing

May be used by 50+ people simultaneously

- Check out the `who` command
- Jobs should have no interference by other people
- Want jobs carefully arranged on compute nodes

Jobs, Queues, and SLURM

Jobs

Vocabulary

Connecting

Modules

Types of Work

Good
Citizenship

Jobs, Queues,
and SLURM

Jobs

Queues

SLURM

Life of a Job

Jobs are submitted to the cluster:

- Cluster executes jobs on back-end compute nodes
- Jobs are carefully scheduled and arranged on the compute nodes

Jobs, Queues, and SLURM

Jobs

Vocabulary

Connecting

Modules

Types of Work

Good
Citizenship

Jobs, Queues,
and SLURM

Jobs

Queues

SLURM

Life of a Job

Jobs need to specify the resources they require:

- Three basic units:
 - Number of nodes
 - Number of cores
 - Time
- Memory
- Other resources

Cluster will allocate requested resources once they are available. Job starts once resources are allocated.

Jobs, Queues, and SLURM

Jobs

Vocabulary

Connecting

Modules

Types of Work

Good

Citizenship

Jobs, Queues,
and SLURM

Jobs

Queues

SLURM

Life of a Job

The most basic unit you can request is nodes:

- Serial applications probably only need one node
- Parallel applications may need 10s or 100s of nodes

Job should also request how many cores per node it needs:

- Cluster allows your job to use only the cores you request
- Often your job should request all of the cores in a node
- Remember, we want to avoid other people!

Jobs, Queues, and SLURM

Jobs

Vocabulary

Connecting

Modules

Types of Work

Good

Citizenship

Jobs, Queues,
and SLURM

Jobs

Queues

SLURM

Life of a Job

Nodes are physically different pieces of hardware.

A job with 20 nodes and 20 cores each, is **not** 400 threads

- 20 individual computers!
- Program needs to be written with MPI to tie all the nodes together

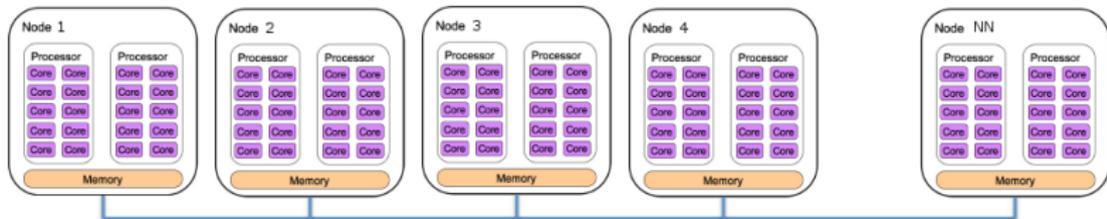

Jobs, Queues, and SLURM

Jobs

Vocabulary

Connecting

Modules

Types of Work

Good
Citizenship

Jobs, Queues,
and SLURM

Jobs

Queues

SLURM

Life of a Job

Nature of the job: how much inter-process communications?

1 core on 20 nodes, or 20 cores on 1 node?

- Communication inside a node is faster than between nodes
- Collisions with other people's jobs (20 nodes \times 19 other jobs = 380 jobs)
- Most performant, most predictable, least vulnerable, least interfering

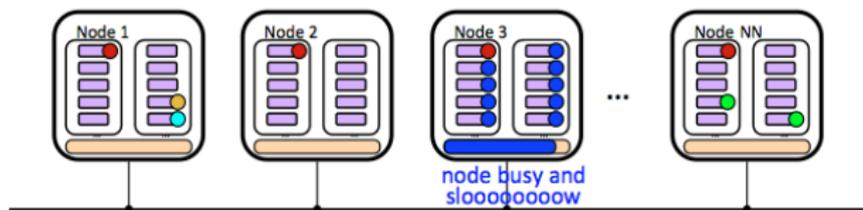

Tight packing preferred. Most ITaP clusters enforce exclusive nodes unless explicitly specified for single node jobs.

Jobs, Queues, and SLURM

Jobs

Vocabulary

Connecting

Modules

Types of Work

Good
Citizenship

Jobs, Queues,
and SLURM

Jobs

Queues

SLURM

Life of a Job

The third basic unit jobs can request is walltime. The cluster won't let your job run forever!

Cluster needs to have a time limit for your job:

- Helps the cluster efficiently schedule you on the nodes
- Make request accurate with some safety buffer
- Tune your walltime request through testing and experimenting

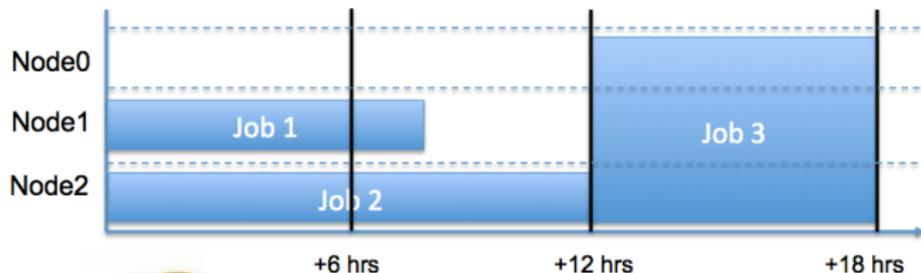

Jobs, Queues, and SLURM

Jobs

Vocabulary

Connecting

Modules

Types of Work

Good
Citizenship

Jobs, Queues,
and SLURM

Jobs

Queues

SLURM

Life of a Job

Provide a memory estimate for your jobs! Slurm controls memory just like nodes and cores.

Slurm will assign a default value if you do not.

This default will be proportional to the number of cores you requested on the node. If you exceed the memory requested per node, even the default, your job will be killed!

Jobs, Queues, and SLURM

Jobs

Vocabulary

Connecting

Modules

Types of Work

Good

Citizenship

Jobs, Queues,
and SLURM

Jobs

Queues

SLURM

Life of a Job

This job asked for the default one core on one node and the default memory slice. On a 20-core node with 64GB per node, if this job exceeds 3GB, it will be killed:

```
$ sbatch myjob.sub
```

This job will be able to use up to 60GB of memory per node:

```
$ sbatch --mem=60G myjob.sub
```

Jobs, Queues, and SLURM

Jobs

Vocabulary

Connecting

Modules

Types of Work

Good
Citizenship

Jobs, Queues,
and SLURM

Jobs

Queues

SLURM

Life of a Job

Memory across multiple compute nodes is distributed. Memory is discrete chunks of memory in different address spaces.

Can't just "add more nodes" to get more memory:

- 20 nodes with 16 GB memory each is **not** 320 GB of memory
- 20 discrete chunks of 16 GB memory
- Can't allocate 320 GB of memory to a single process
- Need MPI to tie memory together



Jobs, Queues, and SLURM

Jobs

Vocabulary

Connecting

Modules

Types of Work

Good
Citizenship

Jobs, Queues,
and SLURM

Jobs

Queues

SLURM

Life of a Job

SLURM is pretty good about isolating jobs from each other (even when they share a node). But if in doubt (or notice effects of contention), simply request an entire node's worth of cores.

Jobs, Queues, and SLURM

Jobs

Vocabulary

Connecting

Modules

Types of Work

Good

Citizenship

Jobs, Queues,
and SLURM

Jobs

Queues

SLURM

Life of a Job

There are a number of other resources you can request in a job:

- Accelerators (GPUs)
- Specific types of nodes
- Certain licenses: MATLAB and its Toolboxes

Jobs, Queues, and SLURM

Queues

Vocabulary

Connecting

Modules

Types of Work

Good

Citizenship

Jobs, Queues,
and SLURM

Jobs

Queues

SLURM

Life of a Job

Cluster can't run all jobs at once so sometimes you must wait

- Jobs are submitted into queues
- Jobs wait until cluster and queue has free resources
- Queues set constraints on jobs that can be submitted
 - Max nodes
 - Max walltime
- Sets initial priorities
- Our clusters have several queue types

Jobs, Queues, and SLURM

Queues

Vocabulary

Connecting

Modules

Types of Work

Good
Citizenship

Jobs, Queues,
and SLURM

Jobs

Queues

SLURM

Life of a Job

Owner queues:

- Named for your PI, lab, or group
- Number of nodes set by what your PI buys into
- Allows for longest jobs - 336 hours
- Jobs should start in 4 hours or less (assuming your queue isn't full of other jobs in the queue)

Queues are **not** tied to specific nodes in the cluster. They allow you to use the number of nodes somewhere in the cluster - whichever nodes are free, functioning, and of the type the queue can access.

Jobs, Queues, and SLURM

Queues

Vocabulary

Connecting

Modules

Types of Work

Good

Citizenship

Jobs, Queues,
and SLURM

Jobs

Queues

SLURM

Life of a Job

Standby queue:

- Uses idle nodes from owner queues
- Everyone on cluster gets access
- Limited to 4 hours (owners must be able get quick access from their queue)
- No limit on number of nodes (probably won't get whole cluster though)
- Lowest priority jobs, no promises on turnaround time (can be minutes or days)
- If you can run under 4 hours, go for it!

Jobs, Queues, and SLURM

Queues

Vocabulary

Connecting

Modules

Types of Work

Good
Citizenship

Jobs, Queues,
and SLURM

Jobs

Queues

SLURM

Life of a Job

Debug queue:

- Allows for running small jobs for testing and debugging
- Up to 2 nodes for 30 minutes at a time
- Highest priority
- Starting time <1 minute

Jobs, Queues, and SLURM

SLURM

Vocabulary

Connecting

Modules

Types of Work

Good
Citizenship

Jobs, Queues,
and SLURM

Jobs

Queues
SLURM

Life of a Job

What is SLURM?

- The Simple Linux Utility for Resource Management (SLURM) is a system providing job scheduling and job management on compute clusters. With SLURM, a user requests resources and submits a job to a queue. The system will then take jobs from queues, allocate the necessary nodes, and execute them.

Jobs, Queues, and SLURM

SLURM

Vocabulary

Connecting

Modules

Types of Work

Good
Citizenship

Jobs, Queues,
and SLURM

Jobs
Queues
SLURM

Life of a Job

What is SLURM, really? It is the resource manager for the cluster:

- Job submission
- Job status
- Schedules jobs
- Executes jobs
- Manages queues
- Manages nodes

Jobs, Queues, and SLURM

Life of a Job

Vocabulary

Connecting

Modules

Types of Work

Good

Citizenship

Jobs, Queues,
and SLURM

Jobs

Queues

SLURM

Life of a Job

You prepare a job submission script

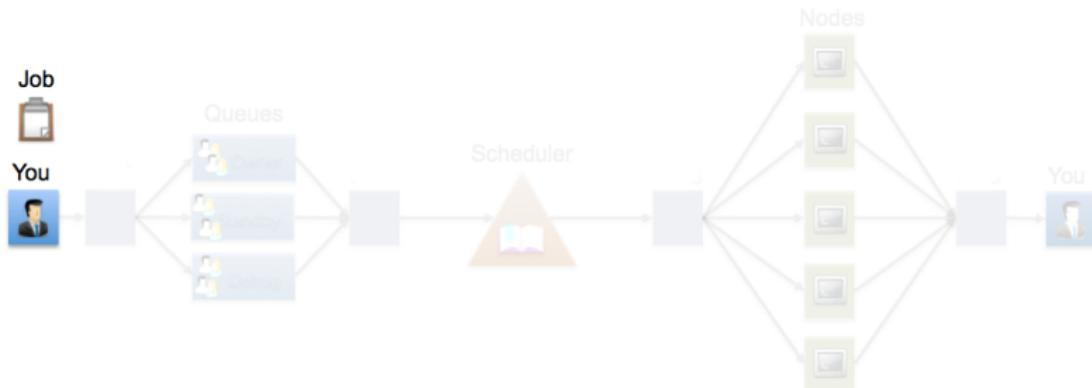

Jobs, Queues, and SLURM

Life of a Job

Vocabulary

Connecting

Modules

Types of Work

Good

Citizenship

Jobs, Queues,
and SLURM

Jobs

Queues

SLURM

Life of a Job

You submit job script into SLURM. The job is placed into a queue.

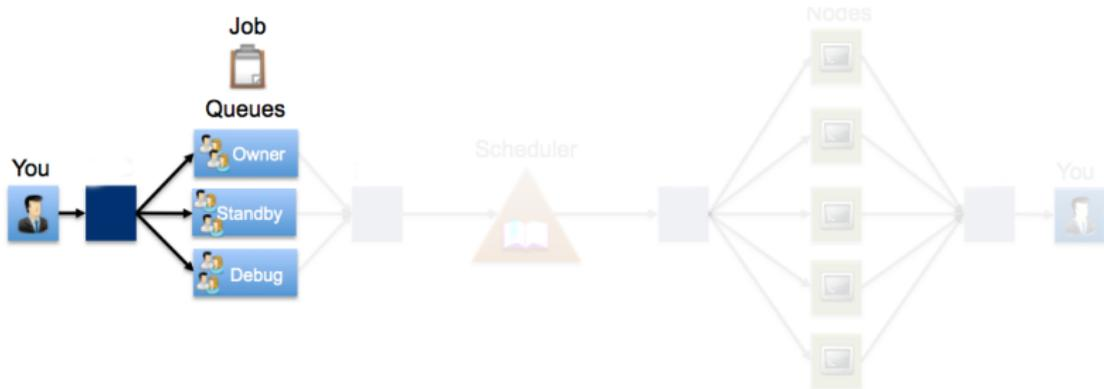

Jobs, Queues, and SLURM

Life of a Job

Vocabulary

Connecting

Modules

Types of Work

Good

Citizenship

Jobs, Queues,
and SLURM

Jobs

Queues

SLURM

Life of a Job

Scheduler iteratively asks for new jobs, status of old jobs, and status of nodes. Each cycle can last several minutes.

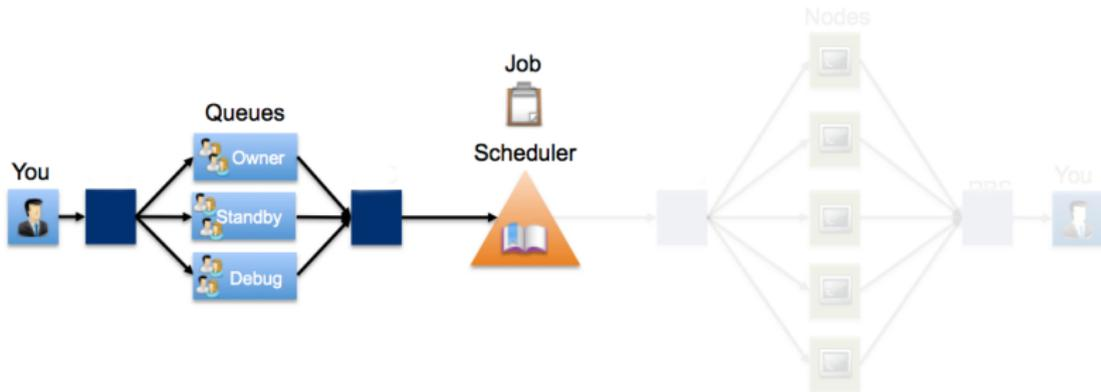

Jobs, Queues, and SLURM

Life of a Job

Scheduler considers jobs, acts as a handler. Tells SLURM to start jobs one at a time. Goes back and does this over and over.

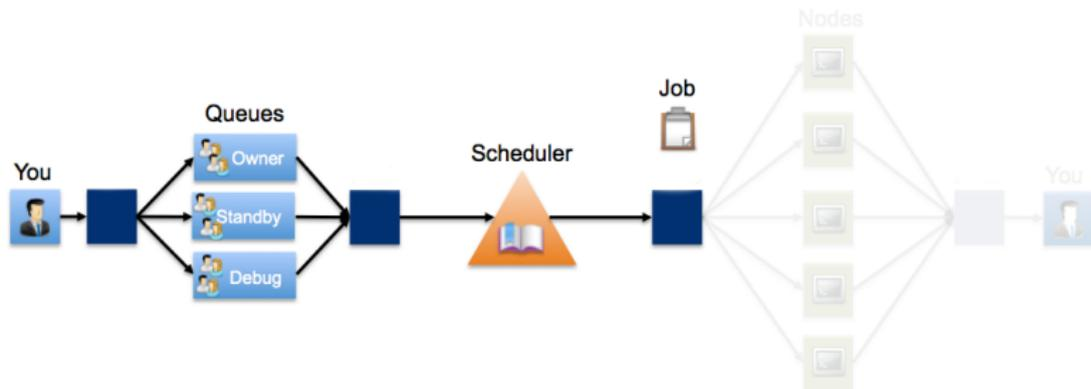

Vocabulary

Connecting

Modules

Types of Work

Good

Citizenship

Jobs, Queues,
and SLURM

Jobs

Queues

SLURM

Life of a Job

Jobs, Queues, and SLURM

Life of a Job

Vocabulary

Connecting

Modules

Types of Work

Good

Citizenship

Jobs, Queues,
and SLURM

Jobs

Queues

SLURM

Life of a Job

SLURM checks health of the node. Send job script to node(s) and executes it.

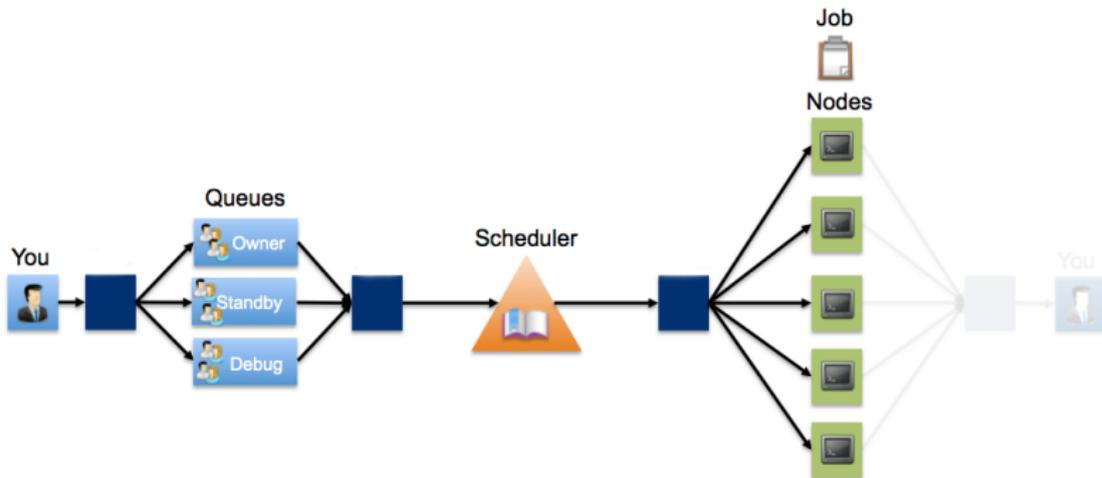

Jobs, Queues, and SLURM

Life of a Job

SLURM watches for the job script to complete on nodes.
Collects job output files from nodes and sends files to you.

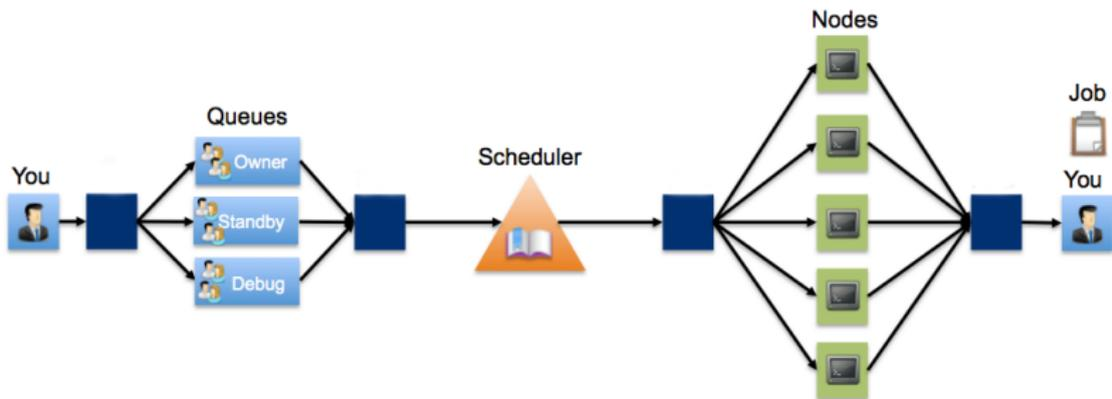

Vocabulary

Connecting

Modules

Types of Work

Good

Citizenship

Jobs, Queues,
and SLURM

Jobs

Queues

SLURM

Life of a Job